

## smart5100



The 5100 series developed as an Outdoor Kiosk provides all the superior features expected from an outdoor kiosk. The product is ideal for urban info terminals and digital services.

### Standard Hardware:

- Waterproof metal cabin resistant to outdoor conditions(IP65)
- Impact-resistant steel keyboard (IP65)
- 15" LCD TFT Panel (ops. 17")
- Infrared Touch-screen
- Via 1.0 GHZ CPU (without fan)
- 512 MB 400MHZ DDR RAM (ops. 1 Gb)
- 60 GB 2,5" Hard Disk
- On board 64 MB VGA
- On board 10/100 Ethernet

### Optional Hardware:

- Phone Receiver
- Card Reader (magnetic or hybrid)
- Thermal Printer (60 mm and 80 mm paper width options)



The Smart5100 series can also be used in hard-to-control public indoor locations with its wall mounted and without-canopy models. The solid structure provides protection against any kind of misuse.

The product can be used form remotely managed digital city networks when used together with the SmartAccess remote management system

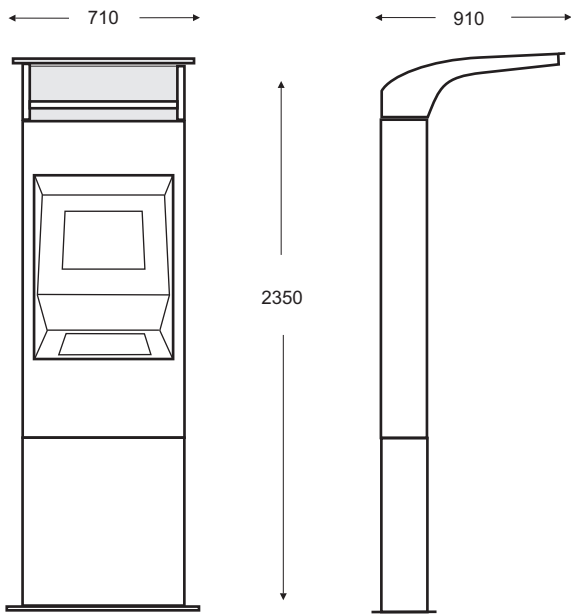

### 5140

Height : 235 cm

Width : 71 cm

Depth : 91 cm (canopy)

Weight : 125 kg

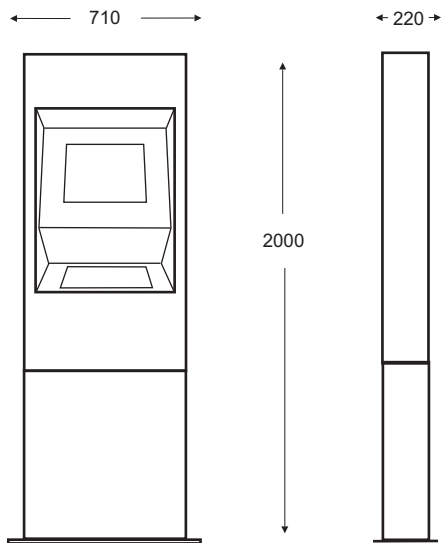

### 5120

Height : 200 cm

Width : 71 cm

Depth : 22

Weight : 90 kg

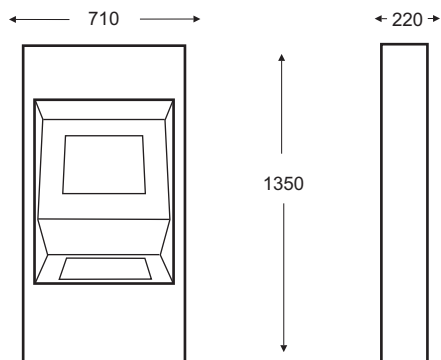

### 5110

Height : 135 cm

Width : 71 cm

Depth : 22 cm

Weight : 40 kg