

smart5500



The 5500 series developed as an Outdoor Kiosk provides practical and fast solutions for outdoor applications.

Standard Hardware:

- Waterproof metal cabin resistant to outdoor conditions
- Impact-resistant steel keyboard
- 15" LCD TFT Panel (ops. 17")
- Infrared Touch-screen
- 2 Watt stereo amplifier, multimedia speakers
- Intel I845GV Chipset
- Intel Celeron D 2.6 GHZ CPU (ops. P4)
- 256 MB 400MHZ DDR RAM (ops. 512 MB)
- 30 GB 2,5" Hard Disk
- On board 64 MB VGA
- On board 10/100 Ethernet

Optional Hardware:

- IP Phone
- Card Reader (magnetic or hybrid)

The Smart5500 series is also provided with floor or wall mounted models and with optional IP Phone and card reader hardware.

The product is ideal for urban info terminals and digital services. You can provide services such as information, applications, transaction tracking, web-based online transactions, ticket sales and ad publishing your facilities or premises.

5510-A

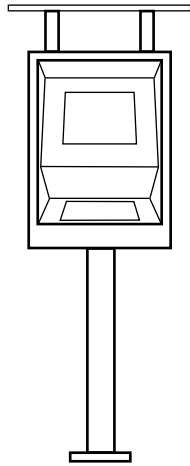

5530-A

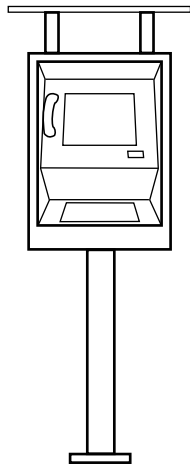

- IP Phone
- Card Reader

5510

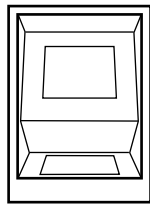

5530

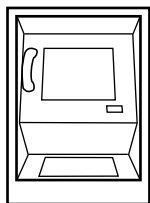

- IP Phone
- Card Reader

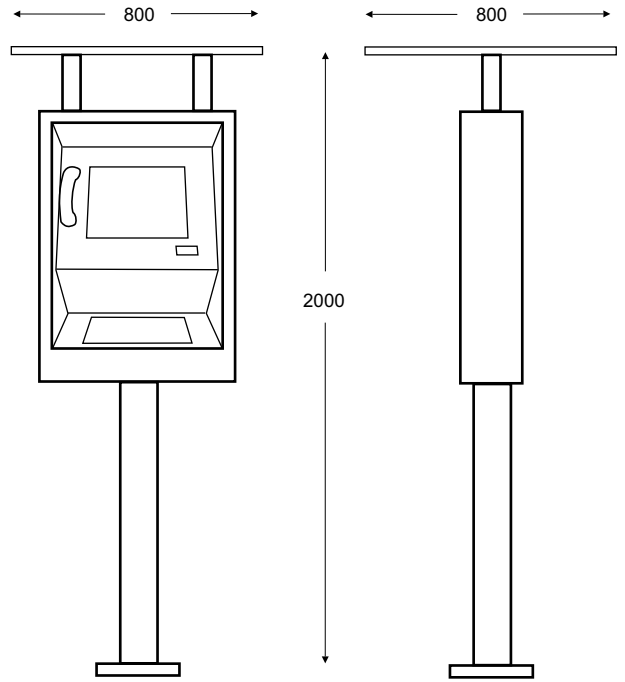

Height : 200 cm

Width : 80 cm (canopy)

Depth : 80 cm (canopy)

Weight : 50 kg

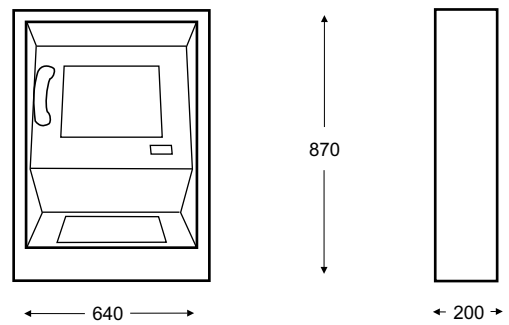

Height : 87 cm

Width : 64 cm

Depth : 20 cm

Weight : 30 kg